

# MS21059 Nutplate Series Specifications

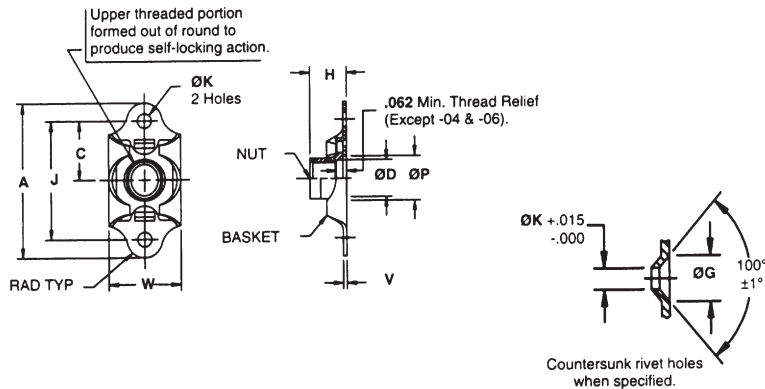

**MATERIAL:** C1050 carbon steel per AMS 5085 (UNS G10500). Heat treat - Rc 49, maximum.

**FINISH:** Cadmium plate per QQ-P-416, Type II, Class 2 and Kaylube molybdenum disulfide dry lubricant per MIL-L-46010.

**FLOATABILITY:** .030 minimum radially from center.

Part Number	Thread (MIL-S-8879)	A Max	C ±.005	D Min	G ±.010	H Max	J ±.005	K +.005 -.000	P REF	V REF	W Max	Approx Weight Lbs/100
MS21059-04	.1120-40 UNJC-3B	.948	.344	-	.200	.153	.688	.098	.250	.020	.416	.31
MS21059-06	.1380-32 UNJC-3B	.948	.344	-	.200	.170	.688	.098	.250	.020	.416	.34
MS21059-08	.1640-32 UNJC-3B	.948	.344	.168	.200	.250	.688	.098	.250	.020	.416	.36
MS21059-3	.1900-32 UNJF-3B	.948	.344	.194	.200	.250	.688	.098	.250	.020	.416	.37
MS21059-4	.2500-28 UNJF-3B	1.292	.500	.254	.200	.281	1.000	.098	.312	.020	.516	.66
MS21059-5	.3125-24 UNJF-3B	1.292	.500	.317	.230	.328	1.000	.130	.375	.025	.609	1.09
MS21059-6	.3750-24 UNJF-3B	1.292	.500	.379	.230	.344	1.000	.130	.437	.025	.680	1.33

# MS21061 Nutplate Series Specifications

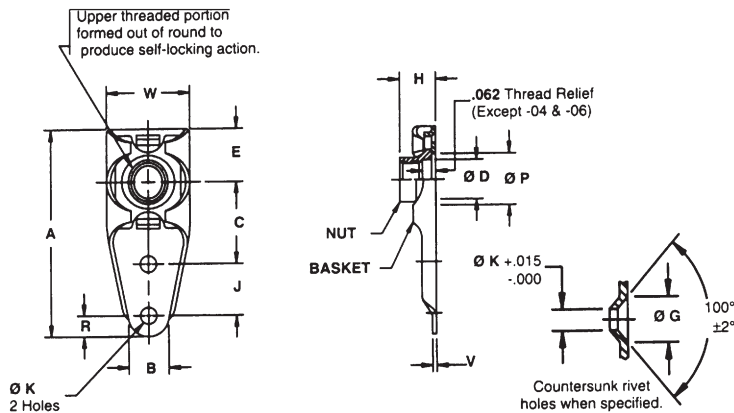

**MATERIAL:** Carbon steel per AMS 5085 (UNS G10500).

**FINISH:** Cadmium plate per QQ-P-416, Type II, Class 2 and Kaylube molybdenum disulfide dry film lubricant per MIL-L-46010.

**PERFORMANCE:** MIL-N-25027

**FLOATABILITY:**  
 -06 through -4: .030 minimum radially from center  
 -5 & up: .025 minimum radially from center

Part Number	Thread (MIL-S-8879)	A Max	B REF	C ±.005	D Min	E REF	G ±.010	H Max	J ±.002	K +.005 -.000	P REF	R REF	V REF	W Max	Approx Weight Lbs/100
MS21061-04	.1120-40 UNJC-3B	1.051	.328	.344	-	.275	.200	.160	.312	.098	.250	.130	.025	.422	.36
MS21061-06	.1380-32 UNJC-3B	1.051	.328	.344	-	.275	.200	.175	.312	.098	.250	.130	.025	.422	.38
MS21061-08	.1640-32 UNJC-3B	1.051	.328	.344	.168	.275	.200	.250	.312	.098	.250	.130	.025	.422	.50
MS21061-3	.1900-32 UNJF-3B	1.051	.328	.344	.194	.275	.200	.250	.312	.098	.250	.130	.025	.422	.50
MS21061-4	.2500-28 UNJF-3B	1.306	.359	.500	.254	.364	.200	.281	.312	.098	.312	.130	.025	.531	.82
MS21061-5	.3125-24 UNJF-3B	1.396	.391	.500	.317	.440	.230	.328	.312	.130	.375	.141	.025	.641	1.45
MS21061-6	.3750-24 UNJF-3B	1.441	.422	.500	.379	.485	.230	.344	.312	.130	.437	.141	.025	.703	1.45