

# 6 Point Captive Washer Series Specifications

## KFN542 Attached Washer Nuts

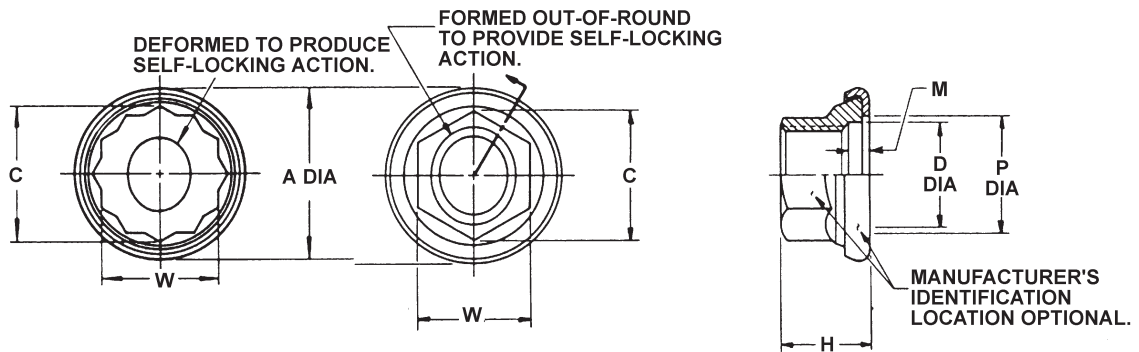

### -9 THROUGH -1612 CONFIGURATION: DOUBLE HEX NUT; -06 THROUGH -8 CONFIGURATION: HEX NUT

Part Number	Threads Per MIL-S-8879	A Max	C Min	D	H Max	M	P Max	W	Axial Tensile Strength Lb Min	Approx Weight Lbs/100
KFN542-06	.1380-32UNJC-3B	.320	.207	.176 .171	.200	.097 .087	.181	.189 .181	1,900	.10
KFN542-08	.1640-32UNJC-3B	.340	.242	.202 .197	.240	.097 .087	.207	.220 .212	2,800	.17
KFN542-836	.1640-36UNJF-3B	.340	.242	.202 .197	.220	.097 .087	.207	.220 .212	2,800	.17
KFN542-3	.1900-32UNJF-3B	.363	.277	.228 .223	.243	.097 .087	.233	.251 .243	3,470	.24
KFN542-4	.2500-28UNJF-3B	.460	.348	.288 .283	.280	.097 .087	.293	.313 .306	6,200	.47
KFN542-5	.3125-24UNJF-3B	.560	.419	.352 .347	.340	.097 .087	.357	.376 .367	9,800	.78
KFN542-6	.3750-24UNJF-3B	.660	.491	.417 .412	.355	.097 .087	.422	.439 .430	13,000	.93
KFN542-7	.4375-20UNJF-3B	.760	.561	.484 .479	.400	.097 .087	.489	.502 .492	18,000	1.44
KFN542-8	.5000-20UNJF-3B	.860	.631	.551 .546	.430	.097 .087	.556	.564 .553	24,000	1.94
KFN542-9	.5625-18UNJF-3B	1.005	.700	.640 .635	.530	.115 .105	.645	.627 .616	33,000	3.08
KFN542-10	.6250-18UNJF-3B	1.100	.846	.710 .705	.575	.115 .105	.715	.752 .741	43,000	5.00
KFN542-12	.7500-16UNJF-3B	1.310	.987	.845 .840	.670	.125 .115	.850	.877 .865	61,000	7.88
KFN542-14	.8750-14UNJF-3B	1.480	1.130	.985 .980	.770	.145 .135	.990	1.002 .990	73,900	11.45
KFN542-1612	1.000-12UNJF-3B	1.690	1.271	1.125 1.120	.870	.165 .155	1.130	1.127 1.115	85,700	16.00

**MATERIAL:** Nut - Alloy steel per MIL-S-6049 (8740), MIL-S-5000 (4340), or MIL-S-5626 (4140)  
Washer - Carbon steel

**HEAT TREAT:** Nut - Rc 39-43 per MIL-H-6875  
Washer - Rc 40-45

**FINISH:** KFN542-(\*) - Nut and washer - Cadmium plated per QQ-P-416, Type II, Class 2.  
(-836 size finish: Cadmium plated per QQ-P-416, Type II, Class 2, plus olive drab chromate finish for identification purposes)

**PERFORMANCE:** KFS1009, except axial tensile strength as tabulated

**APPLICATION:** For use on standard to .032 oversize shank bolts

**PACKAGING:** Parts are normally supplied in bulk packaging. Add "S" after dash number for spindle packaged nuts for use with K-Fast tools (-836 through -5 sizes only).  
Example: KFN542-3S

**NOTES:** "C" and "W" dimensions apply before forming self-locking feature.