

Live Lock Panel Fasteners: General Information

Definitions & Descriptions

1. The **stud-nut** (e.g. CA1820-1; CA1820-3) is retained with the top panel via a retaining ring (CA18377; CA1825; CA1826-1).
2. The **receptacle** (CA18157: rivet on; CA18062: thread in) is mounted in the mating panel.
3. **Spring-loaded ratchet plates** in the receptacles lock the stud into place and resist vibration & loosening WITHOUT THE NECESSITY OF PREVAILING TORQUE; as long as the stud-nut is engaged on the receptacle, it is locked into place. Further tightening does not increase its strength or vibration resistance.
4. **Rated Strength:**
 - 1,650lbs min Ultimate tensile strength
 - 1,800lbs min Ultimate single shear strength thru shank
 - 1,500lbs min Ultimate single shear strength thru recess
5. See illustrations below.

Selection & Care

1. Since both the studs and receptacles employ "4 lead" threads, (#8-32 is the thread size for CA18157, CA18062, CA1820) each full turn of a stud will produce 4 times the vertical thread displacement of a standard #8-32 bolt (e.g. studs will act as if they are #8-8: 8 full turns travel equals 1 inch instead of 32 turns to travel 1 inch).
2. MAXIMUM ENGAGEMENT ON ANY STUD IS 1.75 TURNS; TYPICAL INSTALLATIONS SHOULD BE 1.5 TURNS OR LESS. Remember: FURTHER TIGHTENING DOES NOT ADD TO STRENGTH OR VIBRATION RESISTANCE!!!
3. **FACTORY RECOMMENDED TIGHTENING TORQUE IS 30 lb./in.**
4. The factory recommends that the studs be selected so as not to exceed the grip length ("g" dimension in the chart) indication for each size. Grips close to the maximum for a given stud dash number are sometimes better served with the next longer stud dash number.

Failures

Typically occur in receptacles : cracked, shattered, or broken ratchet plates, caused by (in declining order):

1. **OVER-TIGHTENING:** (attempting to go past coil-bind on the spring).
2. Use of a male stud-nut with a split or otherwise damaged nose, that unevenly contacts and/or "tips" the top ratchet plate.
3. Repeated shock loads (**NEVER USE AIR TOOLS FOR INSTALLATION OR REMOVAL!**) or continuous vibration, which causes the plates to rapidly load and unload against the stud.

Contact us for additional information or for specifications on other Live Lock and Mark IV panel fastener lines.

Typical Live Lock Fastening System:

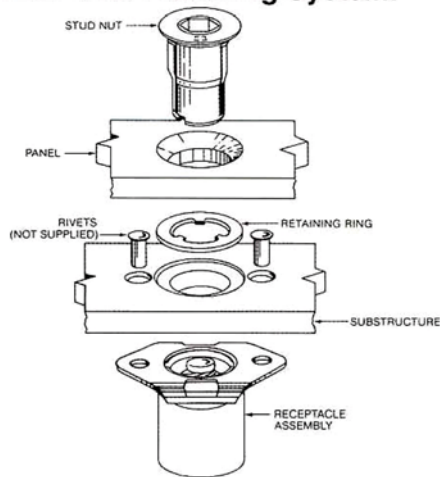

Exploded View

Not shown are optional stud hold-out grommets and cages designed for applications where stud hold-out and bottom flush condition is required. Shims are also available if required.

Locking Mechanism Design Principle: Spring Loaded Ratchet Plates.

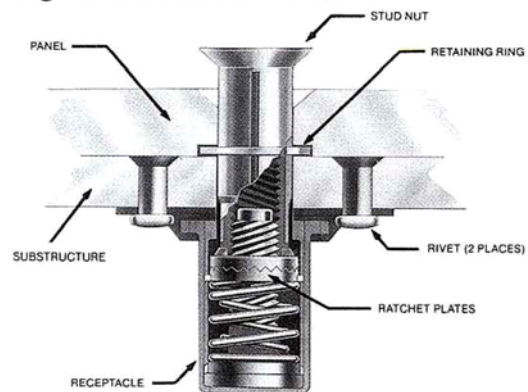

Typical Installation

Spring-loaded ratchet design insures positive locking action and vibration resistance without relying on prevailing torque. Spring(s) nullify effects of resonant vibrations.